

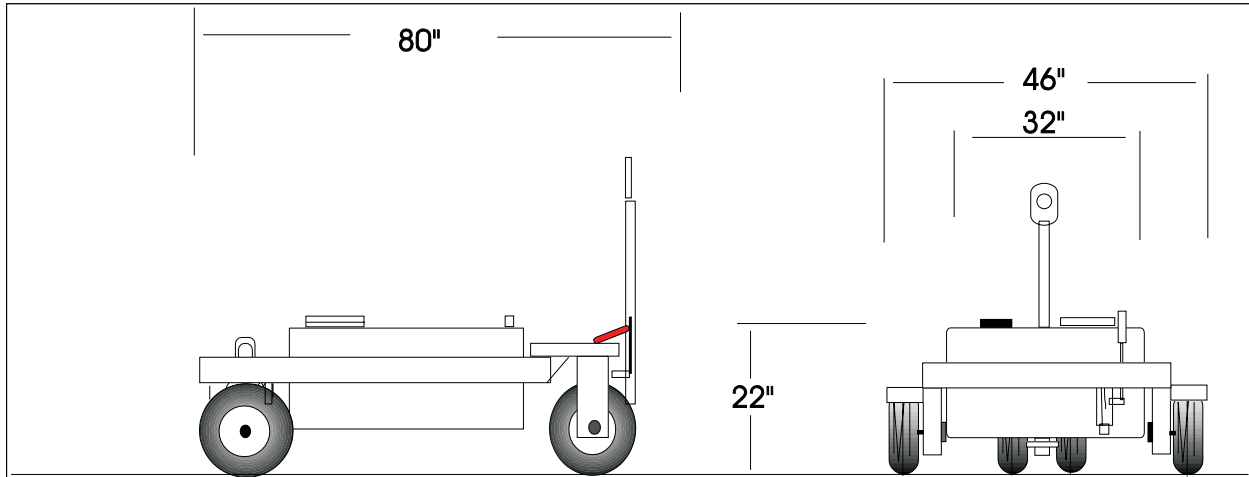

## Water Service Cart

## PNX - WC100LP



### Specifications

#### Tank:

Volume: 100 gallons

#### Features:

- \* Low Profile
- \* Stainless steel tank
- \* Chassis constructed of heavy gauge stainless steel
- \* 4 Heavy duty tires and wheels with tapered bearing
- \* Positive front brake system
- \* Clean out on top of tank
- \* All stainless steel or bronze fittings
- \* Closed fill system
- \* Hand pump
- \* 10' Hose with coupling
- \* Tow bar stainless steel

#### Options:

- \* Hose end parking cushion
- \* Electric pump
- \* Gas engine

#### Shipping Dimensions:

Width: 46"  
Length: 80"  
Height: 22"  
Weight: Approx. 350lbs.

Phoenix Metal Products, Inc., 3000 Industrial Avenue, #3, Ft. Pierce, FL 34946

Phone: 772-595-6386 - Fax: 772-595-6389

Email: [phoenixgse@earthlink.net](mailto:phoenixgse@earthlink.net) URL: [www.phoenixgse.com](http://www.phoenixgse.com)