



PNX-WCH100 LP  
Low Profile  
Potable Water Cart



## Low Profile Potable Water Cart

**PNX - WCH100LP**

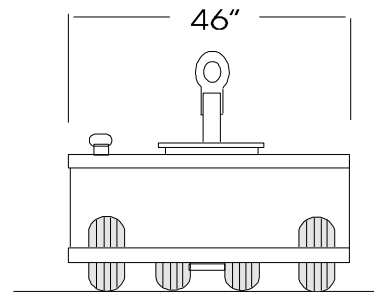
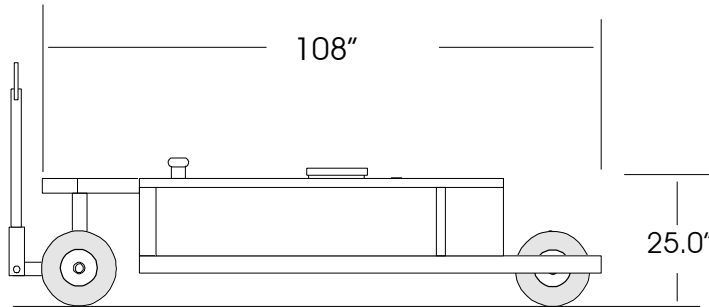

### SPECIFICATIONS

#### TANKS:

100 Gallons

#### FEATURES:

- \* Low profile design
- \* Stainless steel tank
- \* 12" Hinged inspection cover
- \* Chassis constructed of heavy gauge stainless steel tube
- \* 4.10 x 3.5 Pneumatic tires
- \* Front wheel positive brake system
- \* Electric pump with charger
- \* 10' Hose shutoff valve coupling
- \* Hose drain back
- \* Sight gauge
- \* Full insulation top, bottom and sides
- \* Immersion heater with thermostat
- \* Full enclosure
- \* Closed fill system
- \* Tank baffled in both directions
- \* Removable spindles

#### SHIPPING DIMENSIONS:

Width: 46"  
Length: 118"  
Height: 27"  
Weight: Approx. 550 Lb.

**Specification Subject To Change Due To Product Improvement**

**Phoenix Metal Products, Inc., 3000 Industrial Avenue, #3 Ft. Pierce, FL 34946  
Phone: 772-595-6386 - Fax: 772-595-6389  
email: phoenixgse@earthlink.net**