

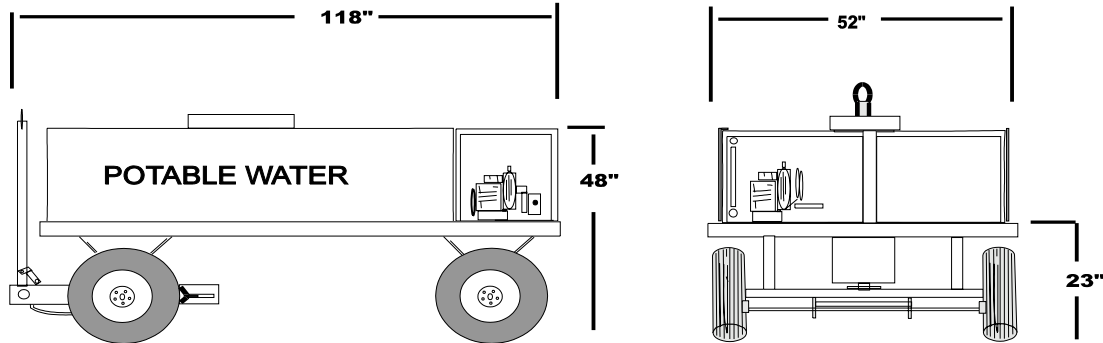

Water Service Cart

PNX - WC400



SPECIFICATIONS

TANK:

400 Gallons

FEATURES:

- * Chassis Constructed of Heavy Gauge 3"x 2" Stainless Steel Tube
- * Heavy Gauge Tubing Axles Galvanized
- * Positive Front Wheel Brake System w/Latch
- * Stainless Steel Top, Bottom & Sides
- * Replaceable Stainless Steel Bolt On Sides
- * 1 3/4" Removable Spindles w/Grease Fittings
- * 570 x 8 Tires and Wheels
- * Stainless Steel Tank
- * Tank Baffled in Both Directions
- * 12" Hinged Cleanout on Top of Tank
- * Closed Fill System
- * Insect Protection
- * 15' Food Grade Hose with Coupling & Shut off Valve
- * Sight Gauge Charge Tank
- * Charge Hose Drain Back
- * 4hp Honda Engine w/Low Oil Shutdown
- * 1/2" Exterior Grade Plywood Tank Cushion
- * Bronze Water Pump

OPTIONS:

- Full Insulation-Top, Bottom & Sides
- Full Enclosure
- Immersion Heater
- Rear Work Platform
- Corner Bumpers
- Electric Start Engine
- Food Grade Rewind Hose Reel
- Emergency Hand Pump

SHIPPING DIMENSIONS:

- Width: 52.5"
- Length: 118"
- Height: 48"
- Weight: Approx. 1900 Lb

Specification Subject to Change Due to Product Improvement

Phoenix Metal Products, Inc., 3000 Industrial Avenue, #3, Ft. Pierce, FL 34946
Phone: 772-595-6386 - Fax: 772-595-6389
email: phoenixgse@earthlink.net