



METAL PRODUCTS, INC.

## PNX-PPS96/150 PASSENGER STAIR

### SPECIFICATIONS

#### 1. Structure

- 1.1 Chassis Heavy Gauge Structural Steel Tubing
- 1.2 Stair Section All Aluminum
- 1.3 Non Skid Stair Steps
- 1.4 Adjustable Top Platform Handrails to Allow for Aircraft Door Opening
- 1.5 Front Solid Tires, Rear Casters

#### 2. Features

- 2.1 Stair Lighting with Battery and Charger
- 2.2 Hand Operated Pump for Hydraulic System
- 2.3 Tow Bar with Storage Brackets
- 2.4 Rear Hydraulic Stabilizer, Casters in Rear
- 2.5 Aluminum Hand Rails

#### 3. Options

- 3.1 Solar Charging System
- 3.2 Two Tone Paint

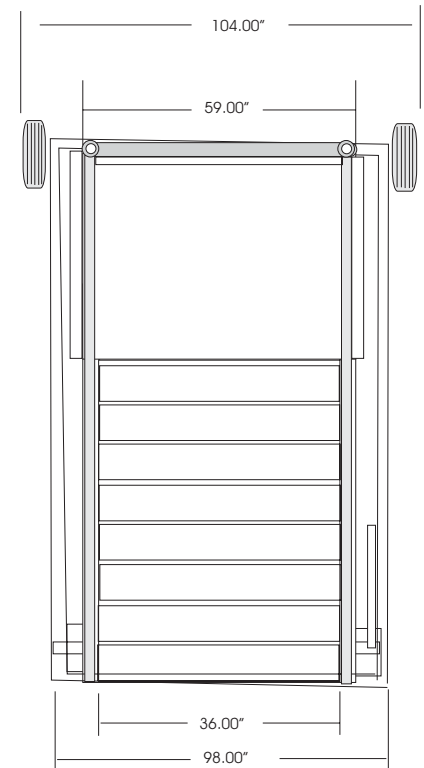
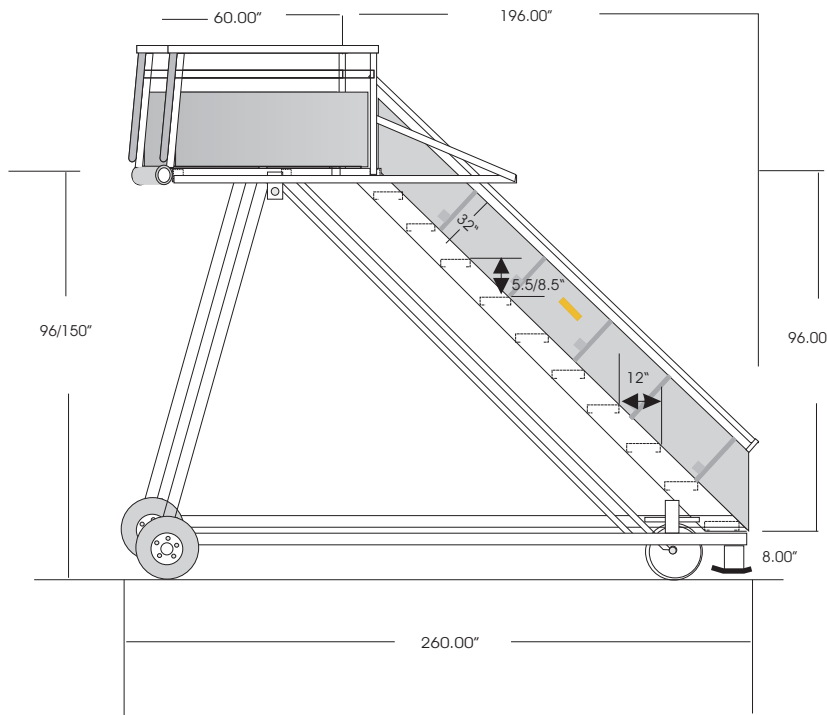

Specification subject to change due to products improvement.

Phoenix Metal Products, Inc. 3000 Industrial Avenue 3-Fort Pierce, FL 34946

Phone: 772-595-6386 Fax: 772-595-6389

Email: phoenixgse@earthlink.net URL: www.phoenixgse.com