

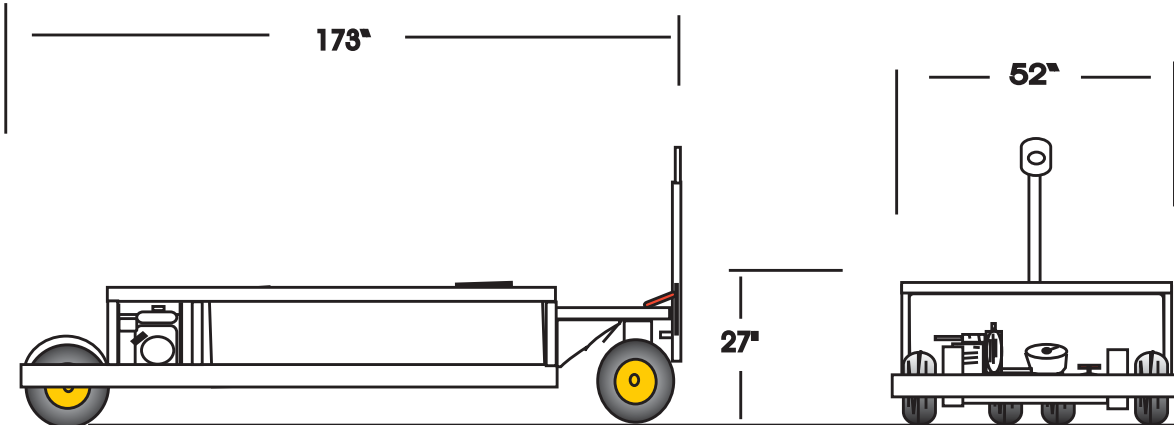

Low Profile Lavatory Service Cart

PNX-LC150/100LP E



Specifications

Tanks:

- * Waste: 150 Gallon
- * Charge: 100 Gallon

Features:

- * Low profile design
- * Stainless steel tanks
- * Positive drain on waste tanks
- * Inspection cover on waste tank
- * Chassis constructed of heavy gauge stainless steel tube
- * 570 X 8 Pneumatic tires
- * Front wheel positive brake system
- * 4hp Honda engine/pump with low oil shutdown
- * 15' Charge hose with valve coupling
- * Charge hose drain back
- * 3' Ball dump valve
- * 10' 4" Waste hose with straight coupling
- * Charge flow meter
- * Waste hose stowage nipple
- * Insect protection
- * Replaceable spindles with grease fitting
- * Sight gauge charge tank
- * Underdrive and towbar galvanized

Options:

- * Full insulation top, bottom and sides
- * Immersion Heater
- * Full enclosure
- * Electric pump

Shipping Dimensions:

- * Width: 52"
- * Length: 173"
- * Height: 27"
- * Weight: Approx. 1500 Lb.

Specification Subject To Change Due To Product Improvement

Phoenix Metal Products, Inc., 3000 Industrial Avenue, #3 Ft. Pierce, FL 34946

Phone: 772-595-6386 - Fax: 772-595-6389

Email: phoenixgse@earthlink.net

URL: www.phoenixgse.com