

# Hy-Lifter

By Phoenix Metal Products, Inc.

## HLM15

## AERIAL PLATFORM

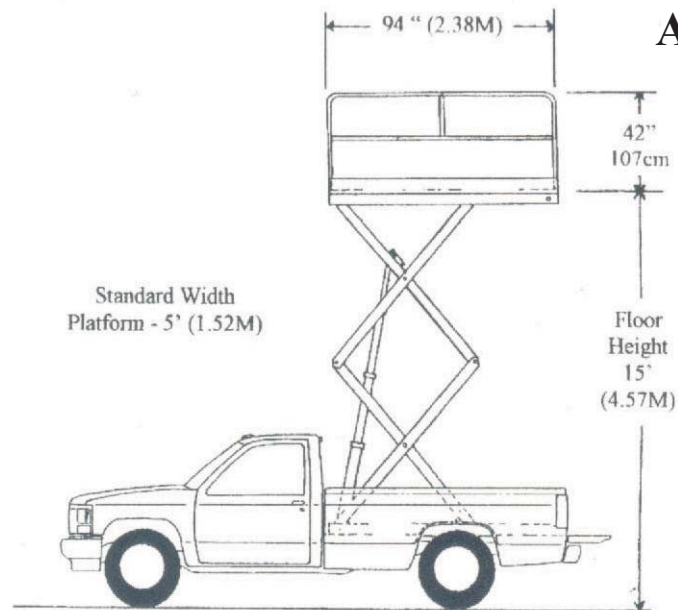

### Specifications

#### Capacity:

8800 lb GVW Truck  
600 lbs.

#### Structure:

- \* Scissor arms are made from 2X4X3/16w structural steel tubing
- \* Precision machined bushings
- \* 100,000 PSI stress proof pivot shafts
- \* Corrosion proof rollers
- \* 1" Round handrails Removeable

#### Platform:

- \* 94"L X 60" W standard
- \* Gripstrut Floor Panels
- \* All welded construction
- \* Pockets for handrails
- \* 1" wide radius handrails

#### Hydraulic:

- \* Self contained 12V DC power unit
- \* 3 Stage telescoping hydraulic cylinder
- \* Low pressure hydraulic system
- \* Safety holding valve
- \* Skydrol resistant hydraulic hoses

#### Electrical:

- \* Upper and lower controls
- \* Lower control override
- \* Emergency electrical letdown
- \* Weather tight control boxes
- \* Fail safe pump relay
- \* Emergency stop

#### Options:

- \* Pendant controls
- \* Platform width 48" & 54"
- \* Tool boxes
- \* Access step
- \* Work lights
- \* Platform rubber bumpers
- \* Lift gate
- \* Skydrol resistant rubber floor covering
- \* Manual electric & hydraulic stabilizers
- \* Galvanized
- \* 19 ft. Height
- \* 20 ft. Height (Requires Stabilizers)

**Phoenix Metal Products, Inc.**

**3000 Industrial Avenue 3 - Fort Pierce, FL 34946**

**Phone: 772-595-6386 Fax: 772-595-6389**

**Email: phoenixgse@earthlink.net URL: www.phoenixgse.com**