

PNX-FSC525

Fuel Service Cart

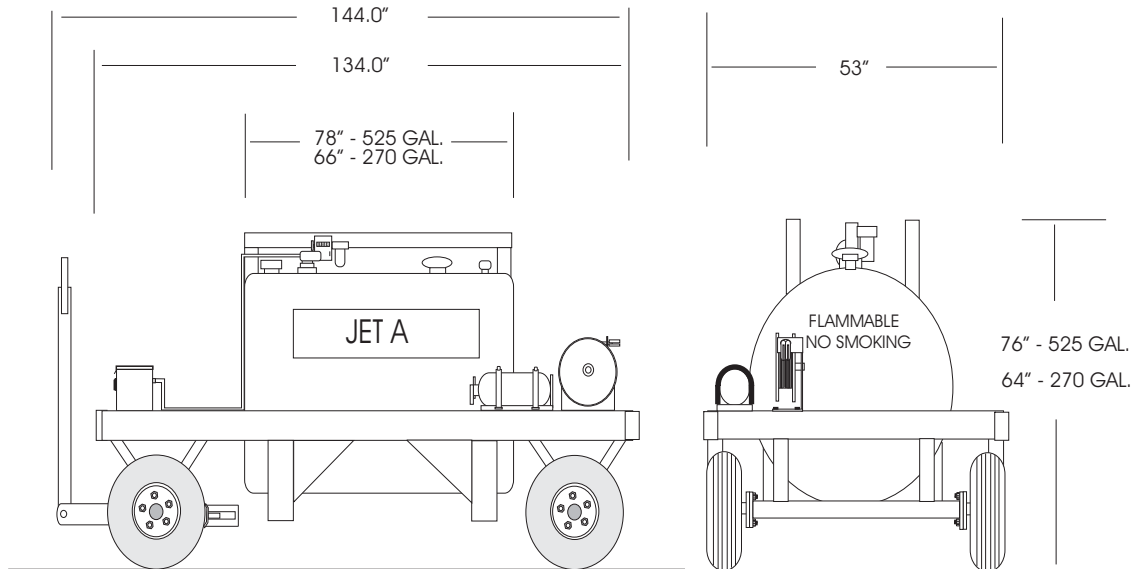

Specifications

Chassis:

- * 3 x 2 x 3/16 Wall structural tubing
- * 5200 LB Axles
- * Fifth wheel steering
- * Locking front brake
- * Shock isolating mounts
- * 4.00 x 8 Soft ride tires

Tank:

- * 12 Gauge double wall construction
- * Level gauge
- * Baffles
- * (2) 4" Emergency vents
- * (1) Standard vent
- * 2" Fill
- * Electric Pump
- * Resettable meter
- * Fuel filter
- * Hose/Nozzle
- * Roll over protection

Safety:

- * Grounding cable reel with 75' and Y branch
- * 20 LB Purple K fire extinguisher
- * Placarding
- * Electric pump wired to meet NEMA 4

Options:

- * 270 Gallons
- * Hand pump
- * Battery and Charger

Specifications Subject to Change Without Notice.

Phoenix Metal Products, Inc. 3000 Industrial Avenue 3 - Fort Pierce, FL 34946
PH 772-595-6386 Fax 772-595-6389
Email Address: phoenixgse@earthlink.net URL: www.phoenixgse.com