



WT700 WATER SERVICE TRUCK

SPECIFICATIONS

TANK:

- Water Tank 700 Gallons
- All Material is Stainless Steel
- All Fittings are Stainless Steel or Bronze
- Fill Gauge
- Hinged Inspection Cover
- Insect Protection

TANK PLATFORM:

- Heavy Gauge 2"x 3" Structural Stainless Steel Tube Frame
- Stainless Steel Bottom and Sides
- 1/2" Exterior Grade Plywood Tank Cushion
- Removable Stainless Steel Exterior Panels
- Access Doors Stainless Steel with Bolt On Stainless Steel Hinges
- Aluminum Tread Plate Top Deck
- Aluminum Rear Splash Guards
- Rubber Rear Top Bumpers

AIRCRAFT SERVICES SYSTEM:

- Electrically Actuated Engine Driven Clutch to Provide Power for Hydraulic System
- Bronze Direct Drive Water Pump
- Stainless Steel Hydraulic Tank w/Filter
- Pumps 20GPM @ 40PSI
- 3/4" Quick Coupling
- 25' Reinforced PVC Hose
- 60 Micron Filter
- Interlock for Pumping in Park
- Rear Step Bumper
- 1 1/4 Tank Drain Valve
- Spring Rewind Hose Reel
- Rear Service Spot Light
- Rear Compartment Service Light
- Closed Tank Fill System
- Rear Indicator Flags

OPTIONS:

- Full Insulation, 2" Bottom, 2" Top & 1" Sides
- Tank Immersion Heater
- Rear Compartment Hot Water Space Heater
- 110 Volt Compartment Space Heater
- Wide Body Personnel Lift
- Electric Pump
- Safety Chocks w/ Holders
- Back Up Alarm
- Amber Flashing Beacon
- Gripstrut Top Deck
- Recessed Top Deck Access Ladder
- Grill and Body Guards
- Transmission Safety Interlock (Locks In Park)
- Hand Brake Interlock
- Hour Meter
- Larger Tank Capacity
- All Stainless Steel Construction
- Available Chassis: Ford, Isuzu, Chevrolet

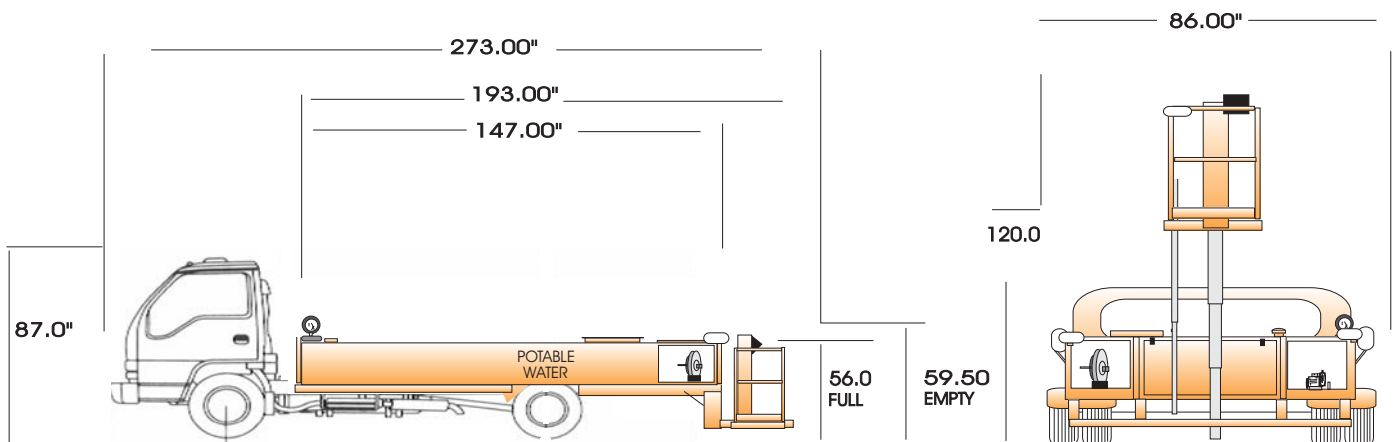

Specification Subject to Change Due to Product Improvement, Chassis Manufacturer Changes or Availability of Chassis

Phoenix Metal Products, Inc., 3000 Industrial Avenue, #3, Ft. Pierce, FL 34946
 Phone: 772-595-6386 - Fax: 772-595-6389
 email: phoenixse@earthlink.net