

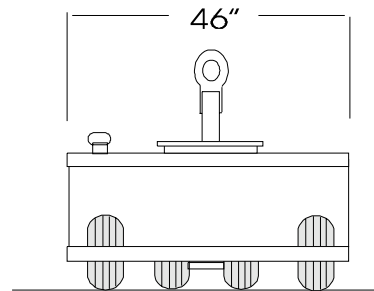

Low Profile Potable Water Cart

PNX - WCH100LP

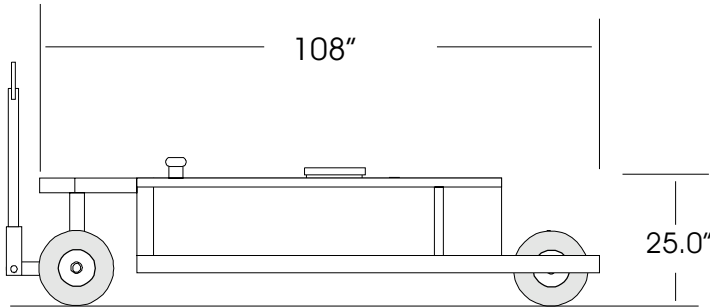

SPECIFICATIONS

TANKS:

100 Gallons

FEATURES:

- * Low profile design
- * Stainless steel tank
- * 12" Hinged inspection cover
- * Chassis constructed of heavy gauge steel tube
- * 4.10 x 3.5 Pneumatic tires
- * Front wheel positive brake system
- * Electric pump with charger
- * 10' Hose shutoff valve coupling
- * Hose drain back
- * Sight gauge
- * Full insulation top, bottom and sides
- * Immersion heater with thermostat
- * Full enclosure
- * Closed fill system
- * Insect protection
- * Tank baffled in both directions
- * Removable spindles

OPTIONS:

- * 4 HP Honda engine/pump with low oil shutdown
- * All stainless steel frame and module

SHIPPING DIMENSIONS:

Width: 46"
Length: 118"
Height: 27"
Weight: Approx. 550 Lb.

Specification Subject To Change Due To Product Improvement

Phoenix Metal Products, Inc., 3000 Industrial Avenue, #3 Ft. Pierce, FL 34946
Phone: 772-595-6386 - Fax: 772-595-6389
email: phoenixgse@earthlink.net