

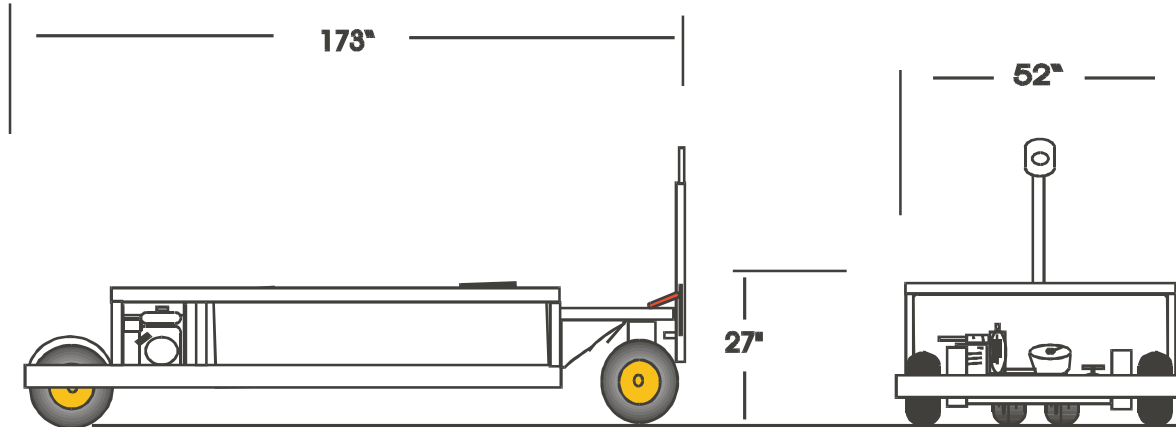

Low Profile Potable Water Service Cart

PNX – WC250LP



SPECIFICATIONS

Tanks:

250 Gallons

Features:

- * Low profile design
- * Stainless steel tank
- * Positive drain on tank
- * 12" Hinged inspection cover
- * Chassis constructed of heavy gauge stainless steel tube
- * 570 X 8" Pneumatic wheels
- * Front wheel positive brake system
- * 4hp Honda engine/pump w/low oil shutdown
- * 15' Hose w/valve and coupling
- * Hose drain back
- * Galvanized under drive and tow bar

Options:

- * Full insulation top, bottom and sides
- * Immersion heater w/thermostat
- * Full enclosure
- * Electric pump

Shipping Dimensions:

Width: 52"
Length: 173"
Height: 27"
Weight: Approx. 1500 lb.

Specification Subject to change due to product improvement.

Phoenix Metal Products, Inc. 3000 Industrial Avenue 3-Fort Pierce, FL 34946

Phone: 772-595-6386

Fax: 772-595-6389

Email: phoenixgse@earthlink.net

URL: www.phoenixgse.com