

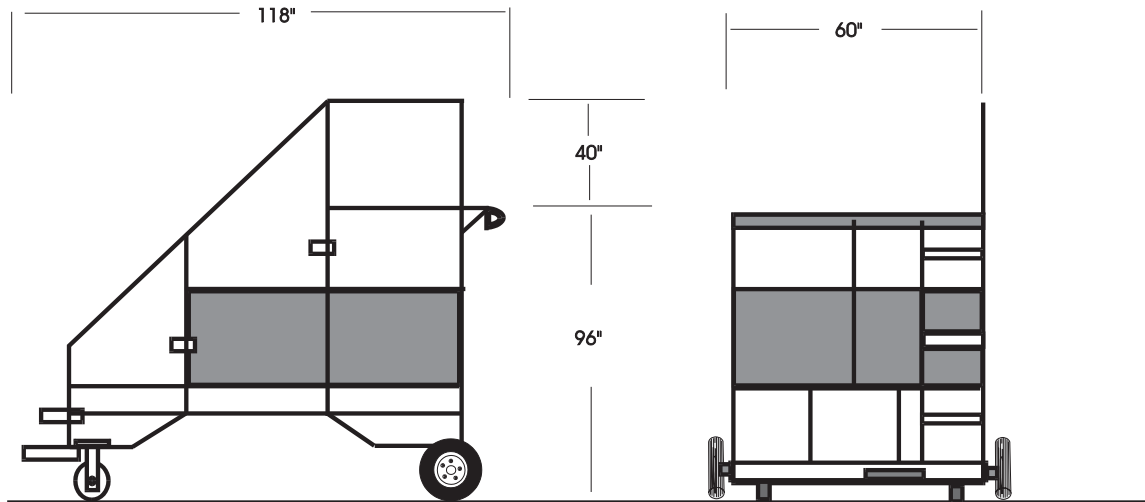

## Provision Stand

PS-96



## SPECIFICATIONS

### Service Dimensions

Width: 60"  
 Length: 118"  
 Height: 96" deck height

### Tires \ Wheels

- Tires are 4.00 X 8.00 Soft Ride Solid Tires on 5 @ 4.5 Steel Split Rims
- 8" Polyurethane Swivel Casters

### Features:

- Constructed of 1" Square Tubing
- Heavy Gauge Non Slip Deck
- Grip Strut Steps
- Interchangeable Handrail-Left Side/Right Side
- Removable Handrail for Shipping
- Heavy Wall 2' X 3" Tube Axle
- Main Deck Enclosed with Perforated Galvaneal
- 4" "D" Bumper
- 1 3/4" Removable Spindles with External Grease Fitting
- Positive Brake System/Both Tires
- Easily Maneuvered

### Options:

Available in 94" and 111"

### SHIPPING DIMENSIONS:

Width: 60"  
 Length: 118"  
 Height: 96"  
 Weight: Approx. 950 Lb.

Specification Subject to Change Due to Product Improvement

Phoenix Metal Products, Inc., 3000 Industrial Avenue, #3, Ft. Pierce, FL 34946  
 Phone: 772-595-6386 - Fax: 772-595-6389  
 Email: [phoenixgse@earthlink.net](mailto:phoenixgse@earthlink.net) URL: [www.phoenixgse.com](http://www.phoenixgse.com)