

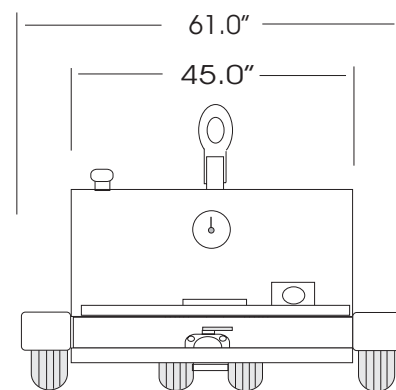

## Low Profile Lavatory Service Cart

PNX-LC60/40LP

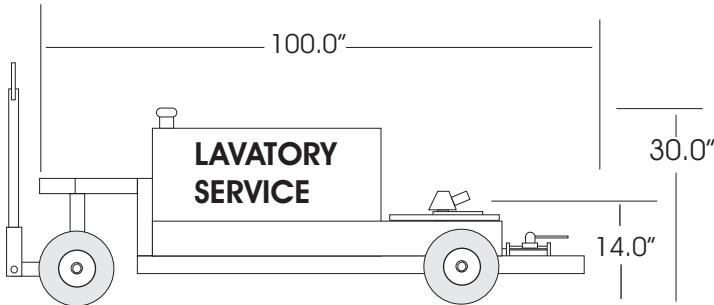

### Specifications

#### Tanks:

- \* Waste: 60 gallons
- \* Charge: 40 gallons

#### Features:

- \* Low profile design
- \* Stainless steel tanks
- \* Positive drain on waste tank
- \* 12" Hinged inspection cover on waste tank
- \* Chassis constructed of heavy gauge tube
- \* 4.10 X 3.5 Pneumatic tires
- \* Front wheel positive brake system
- \* Electric pump with charger
- \* 15' Charge hose with shutoff valve
- \* Charge hose drain back
- \* 3" Ball dump valve
- \* 8' 4" Waste hose with straight coupling
- \* Dial face meter
- \* Waste hose stowage nipple
- \* Insect protection
- \* Sight gauge flush tank

#### Options:

- \* Full insulation, top bottom & sides
- \* Immersion heater and thermostat
- \* Closed dump adapter

#### Shipping Dimensions:

Width: 61"  
 Length: 106"  
 Height: 30"  
 Weight Approx: 550 lbs.