

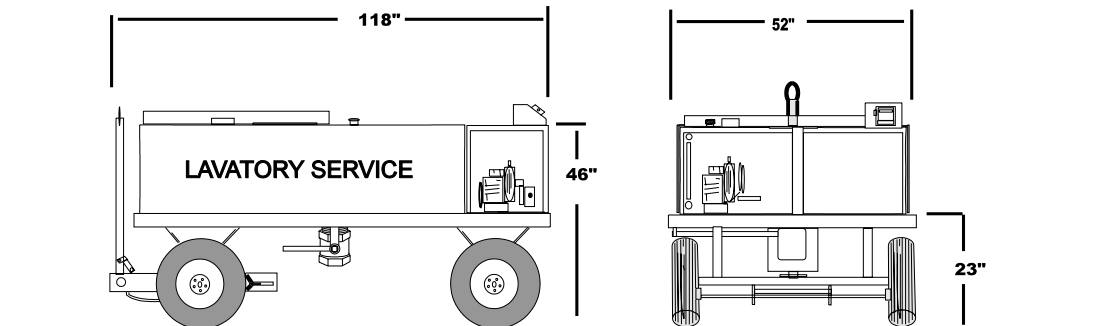

Lavatory Service Cart

PNX-LC250/150



Specifications

Tanks:

- * Waste: 250 Gallon
- * Charge: 150 Gallon

Features:

- * Chassis constructed of heavy gauge 3" x 2" stainless steel tube
- * Heavy gauge tubing axles galvanized
- * Positive front wheel brake system w/latch
- * Stainless steel top bottom & sides
- * 1 3/4" Removable spindles w/grease fittings
- * 570 x 8 Tires and Wheels
- * Stainless steel tanks
- * Tanks baffled in both directions
- * Inspection cover on waste tank
- * Waste hose stowage tray w/stowage nipple
- * Waste inlet swivel
- * Insect protection
- * 10' Waste hose
- * 15' Charge hose w/coupling and valve
- * Sight gauge charge tank
- * Charge hose drain back
- * 4hp Honda engine w/low oil shutdown
- * Enclosed resetable flow meter mounted on top
- * 4" Ball dump valve
- * 1/2 Exterior grade plywood tank cushion
- * Bolt on removable sides
- * Galvanized tow bar

Options:

- * Full insulation-top, bottom and sides
- * Full enclosure
- * Immersion heater
- * 757 Service platform w/access steps
- * Rear work platform
- * Closed dump system
- * Corner bumpers
- * Wye coupling
- * Electric start engine
- * Rewind hose reel
- * Emergency hand pump

Shipping Dimensions:

- Width: 52.5"
- Length: 118"
- Height: 48"
- Weight: Approx. 1900 LB.

Specification Subject to Change Due to Product Improvement

Phoenix Metal Products, Inc., 3000 Industrial Avenue, #3, Ft. Pierce, FL 34946
 Phone: 772-595-6386 - Fax: 772-595-6389
 Email: phoenixgse@earthlink.net URL: www.phoenixgse.com