

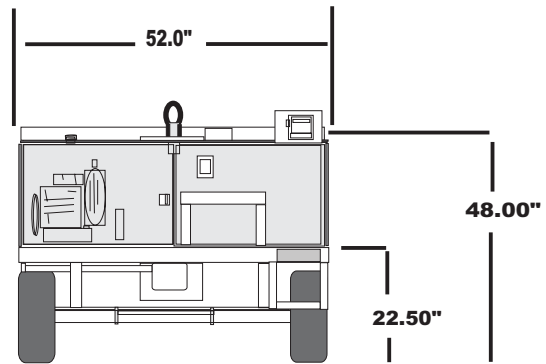

## Lavatory Service Cart

## PNX-LC250/150 PL

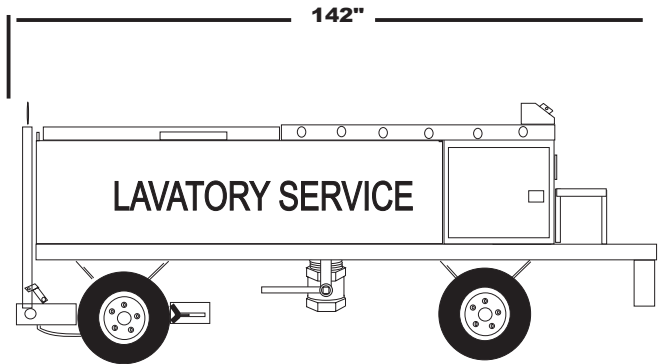

## SPECIFICATIONS

### **TANKS:**

Waste: 250 Gallon  
Charge: 150 Gallon

### **FEATURES:**

- \* Chassis constructed of heavy gauge 3"x2" stainless steel tube
- \* Heavy gauge tubing axles galvanized
- \* Positive front wheel brake system with latch
- \* Stainless steel top, bottom and sides
- \* 1 3/4" Removable spindles w/grease fittings
- \* 570 X 8 Tires and wheels
- \* Stainless steel tanks
- \* Tanks baffled in both directions
- \* Hinged inspection cover
- \* Waste hose stowage tray w/stowage nipple
- \* Insect protection
- \* 4" Ball valve dump
- \* 12' Waste hose
- \* 15' Charge hose w/ coupling and valve
- \* Sight gauge charge tank
- \* Charge hose drain back
- \* 4HP Honda engine w/ low oil shutdown
- \* Resettable flow meter
- \* Gripstrut top on platform for 757 service w/ Access steps
- \* Bolt On Removable Sides
- \* Galvanized Tow Bar

### **FEATURES CONTINUED:**

- \* Rear gripstrut work platform
- \* Stainless steel bolt on door hinge
- \* Corner protection
- \* 1/2" Exterior grade plywood tank cushion
- \* 1 1/4" Flush tank drain

### **OPTIONS:**

- \* Closed dump system
- \* Kaiser aluminum "Y" coupling
- \* 1" Shear Coupling
- \* Full insulation top, bottom and sides
- \* Immersion heater
- \* Charge hose shear coupling
- \* Full enclosure
- \* Corner bumpers
- \* Rewind hose reel
- \* Electric 5.5 HP Honda engine
- \* Emergency hand pump

### **SHIPPING DIMENSIONS:**

Width: 52"  
Length: 142"  
Height: 48"  
Weight: Approx. 2300 lbs.

**Specification Subject to Change Due to Product Improvement**  
**Phoenix Metal Products, Inc. 3000 Industrial Avenue, #3, Ft. Pierce, FL 34946**  
**Phone: 772-595-6386 - Fax: 772-595-6389**  
**Email: [phoenixgse@earthlink.net](mailto:phoenixgse@earthlink.net) URL: [www.phoenixgse.com](http://www.phoenixgse.com)**