

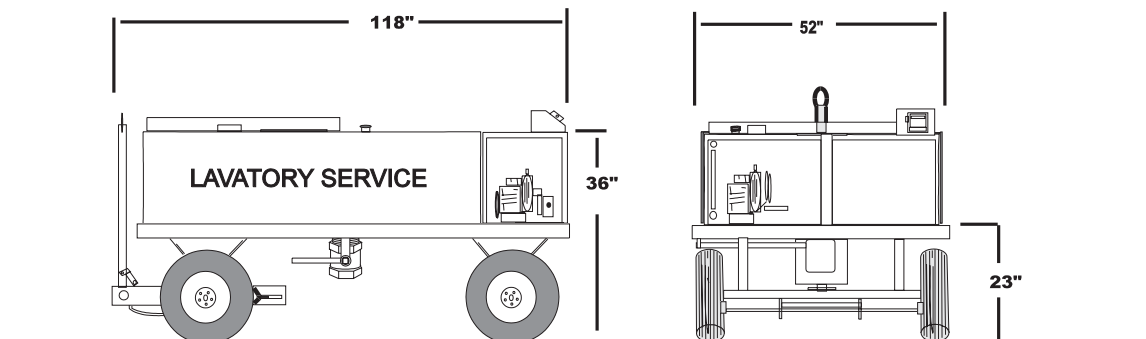

Lavatory Service Cart

PNX - LC150-100



Specifications

Tanks:

- * Waste: 150 Gallons
- * Charge: 100 Gallons

Features:

- * Chassis is constructed of heavy gauge 3" x 2" stainless steel tube
- * Heavy Gauge Galvanized Tubing Axles
- * Positive front wheel braking system w/latch
- * Stainless steel top, bottom and sides
- * Replaceable bolt on sides
- * 1 3/4" Removeable spindles w/grease fittings
- * 570 x 8 Tires and wheels
- * Stainless steel tanks
- * Tanks baffled in both directions
- * Hinged inspection cover on waste tank
- * Waste hose stowage tray w/stowage nipple
- * Insect protection
- * 10' Waste hose
- * 15' Charge hose with coupling and valve
- * Sight gauge charge tank
- * Charge hose drain back
- * Waste inlet swivel
- * 4hp Honda engine w/low oil shutdown
- * Enclosed resetable flow meter mounted on top
- * 4" Ball dump valve
- * 1/2" Exterior grade plywood tank cushion
- * Galvanized Tow Bar

Options:

- * Full insulation top, bottom and sides
- * Full enclosure
- * Immersion heater
- * Rear work platform
- * Closed dump system
- * Corner bumpers
- * Wye coupling
- * Electric start engine
- * Emergency hand pump
- * All stainless steel frame and module construction

Shipping Dimensions:

Width: 52"
Length: 118"
Height: 41"
Weight: Approx. 1450 lbs.

Specification Subject to Change Due to Product Improvement
Phoenix Metal Products, Inc., 3000 Industrial Avenue, #3, Ft. Pierce, FL 34646
Phone: 772-595-6386 - Fax: 772-595-6389
Email: phoenixgse@earthlink.net
URL: www.phoenixgse.com