



PNX-FSC525

Fuel Service Cart



The Phoenix Metal Products FSC525 is a service cart to refuel ground support equipment. The FSC utilizes a fifth wheel front steering system with a front brake when the tongue is in the upright and locked position. The chassis is constructed of heavy wall structural tubing and the design incorporates a low center of gravity. The tank is supported on four corners by shock isolators. The tank is double wall construction, eliminating the need for a containment berm. The tank includes baffles, emergency vents and a self-closing fill cap. All electrical components are U.L. labeled and the FSC meets Nema 4 specifications. A grounding cable reel and 20 LB Purple K fire extinguisher are standard.

PNX-FSC525

Fuel Service Cart

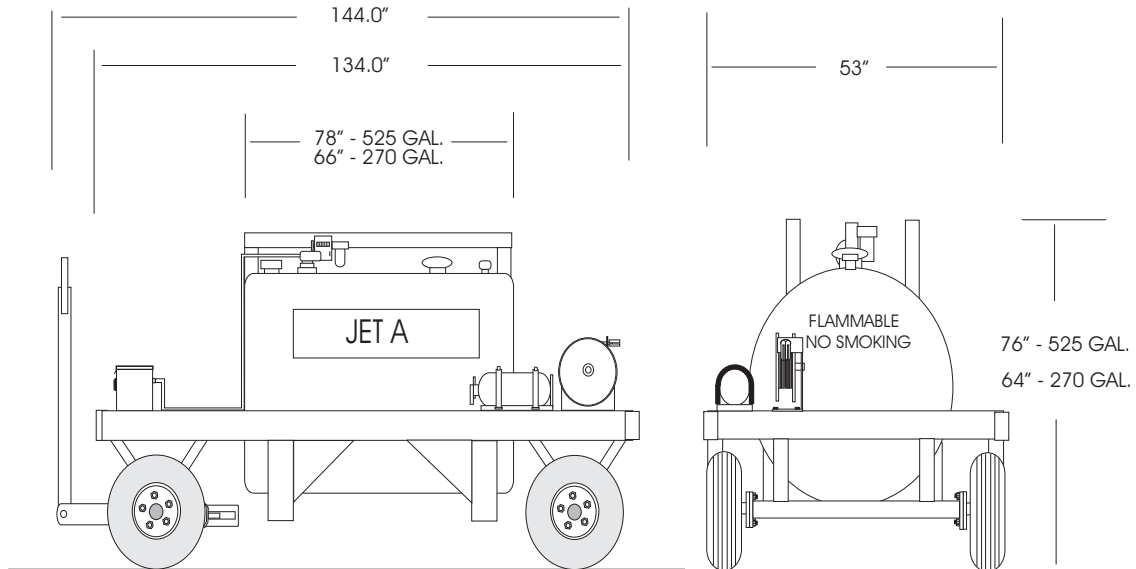

Specifications

Chassis:

- * 3 x 2 x 3/16 Wall structural tubing
- * 5200 LB Axles
- * Fifth wheel steering
- * Locking front brake
- * Shock isolating mounts
- * 4.00 x 8 Soft ride tires

Tank:

- * 12 Gauge double wall construction
- * Level gauge
- * Baffles
- * (2) 4" Emergency vents
- * (1) Standard vent
- * 2" Fill
- * Electric Pump
- * Resettable meter
- * Fuel filter
- * Hose/Nozzle
- * Roll over protection

Safety:

- * Grounding cable reel with 75' and Y branch
- * 20 LB Purple K fire extinguisher
- * Placarding
- * Electric pump wired to meet NEMA 4

Options:

- * 270 Gallons
- * Hand pump
- * Battery and Charger

Specifications Subject to Change Without Notice.

Phoenix Metal Products, Inc. 3000 Industrial Avenue 3 - Fort Pierce, FL 34946
PH 772-595-6386 Fax 772-595-6389
Email Address: phoenixgse@earthlink.net URL: www.phoenixgse.com