

PNX-FSC270-2

Fuel Service Cart

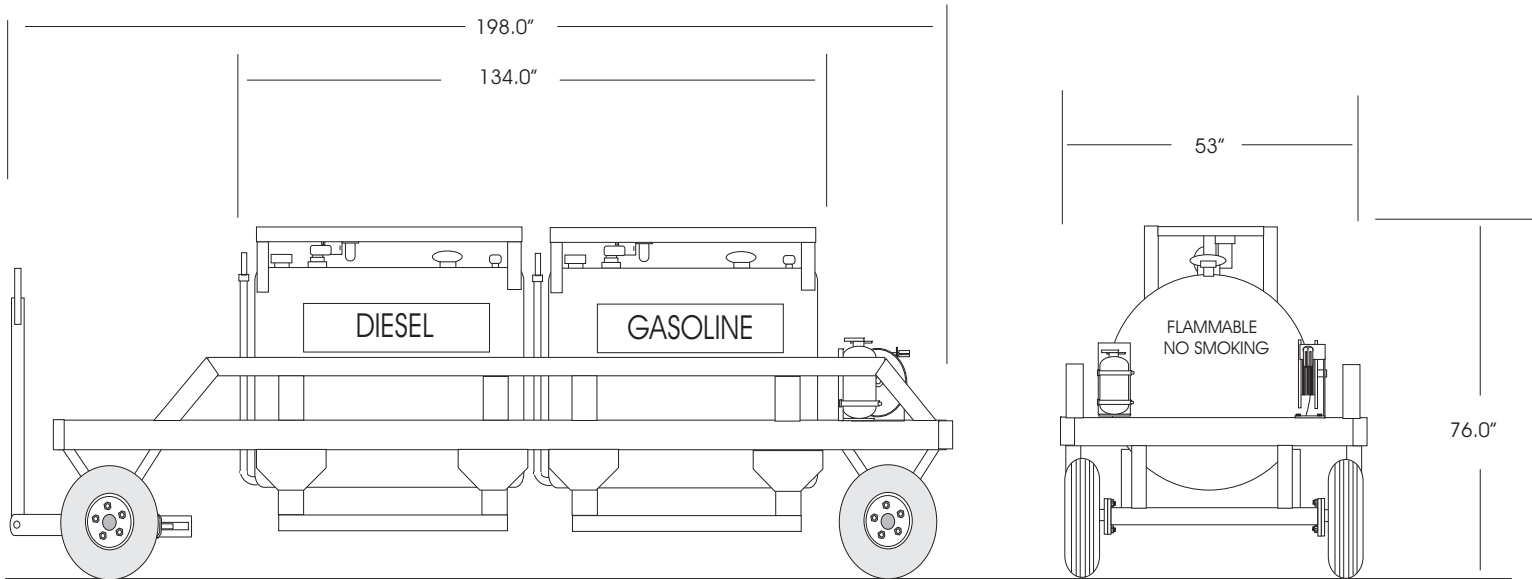

Specifications

Chassis:

- * 3 x 2 x 3/16 Wall structural tubing
- * 5200 LB Axles
- * Fifth wheel steering
- * Locking front brake
- * Shock isolating mounts
- * 4.00 x 8 Soft ride tires

Safety:

- * Grounding cable reel with 75' and Y branch
- * 20 LB Purple K fire extinguisher
- * Placarding per fluid type
- * Electric pump wired to meet NEMA 4
- * Weatherproof electrical plug for fuel pump power from towing vehicle

Tanks:

- * (2) 270 gallon capacity
- * 12 Gauge double wall construction
- * Level gauge
- * Containment tank leak gauge
- * Baffles
- * (1) 4" Emergency vent
- * (1) Standard vent
- * (1) 2" Self closing Fill cap
- * Electric Fuel Transfer Pump - 12V DC Explosion proof
- * Resettable meter
- * Fuel filter
- * Hose with positive closing squeeze nozzle
- * Roll over protection

Dimensions:

Length	198.00"
Width	52.00"
Height	76.00"
Weight	4500 lbs

Specifications Subject to Change Without Notice.

Phoenix Metal Products, Inc. 3000 Industrial Avenue 3 - Fort Pierce, FL 34946

PH 772-595-6386 Fax 772-595-6389

Email Address: phoenixgse@earthlink.net URL: www.phoenixgse.com