

# **PHOENIX**

## **METAL PRODUCTS, INC.**



The Phoenix CMPPS96/150 is a chassis mounted, passenger, parallelgram stair. It is designed for the rugged nature of airport ramp operation. The chassis is a heavy duty formed chassis. The stair is a parallelgram design and is made of structural aluminum..

The drive line consists of a heavy duty front and rear axles and can be outfitted with different engines..

The stair is stabilized at all four corners and has adjustable sliding wings at the platform. The stair will service aircraft with doorsill between 96" and 150".

The stair has lighting for night service. The stair is supported by two lifting cylinders with hydraulic locking valves. The unit comes standard with: electrical emergency pump, instrument gauges and non-skid decking.

# PHOENIX CMPPS 96/150

# MOBILE PASSENGER STAIR

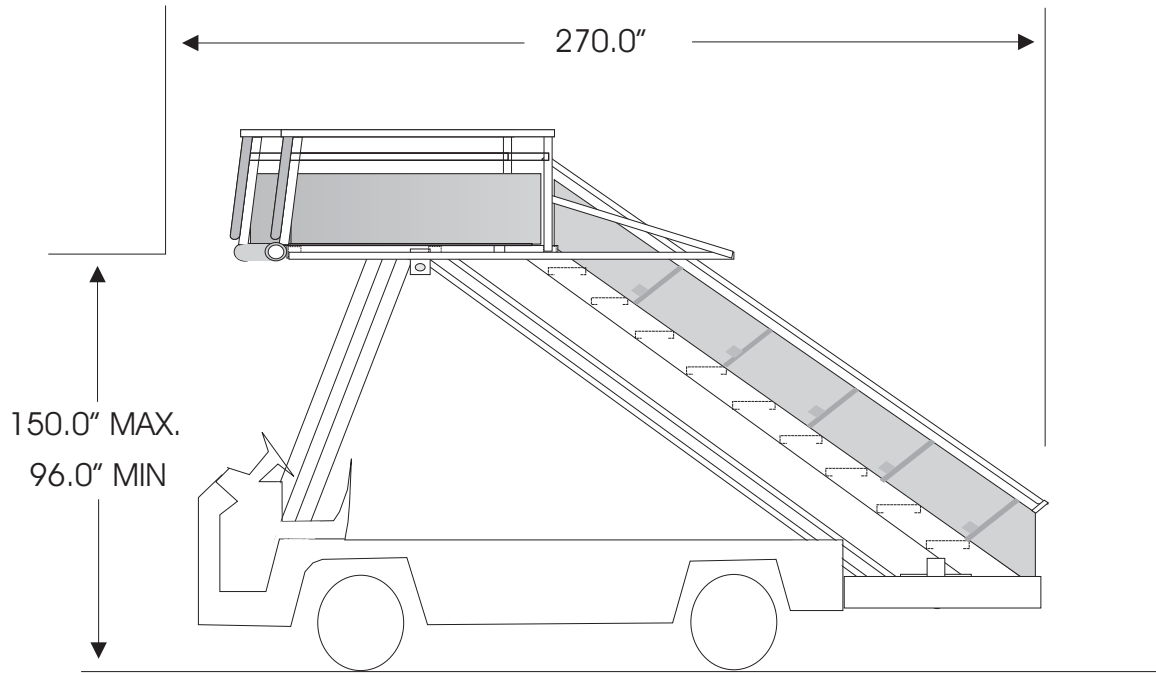

## SPECIFICATIONS

### CHASSIS:

HEAVY DUTY SHEET METAL WITH 3/8 STEEL  
PLATE FRONT AND REAR

### SUSPENSION:

SOLID MOUNT FRONT AND REAR

### STEERING:

HYDROSTATIC - ORBITROL/ CYLINDER

### AXLES:

DRIVE AXLE - DANA 60 LIMITED SLIP - 7.17:1 RATIO

STEER AXLE - DANA 60

### BRAKES:

DUAL SPLIT SYSTEM - HYDRAULIC ASSIST

FRONT DISC - REAR DRUM

### ELECTRICAL SYSTEM:

12 VOLT - NEGATIVE GROUND

60 AMP ALTERNATOR

### HYDRAULIC SYSTEM:

ENGINE DRIVEN - POSITIVE DISPLACEMENT

EMERGENCY PUMP

### TRANSMISSION:

FORD INDUSTRIAL C6

DIESEL - 3 SPEED

### ENGINE:

PERKINS 1104C.44 4CYL DIESEL

DEUTZ DIESEL - F4M2011 3.1L 4 CYL OIL COOLED

### FEATURES:

4 CORNER STABILIZERS

STAINLESS STEEL HYDRAULIC AND FUEL TANK

MANUAL LIFT AND STABILIZER CONTROLS:

ENGINE COOLANT AND LOW OIL PRESSURE SAFETY

HANDBRAKE/ NEUTRAL SAFETY

RUB RAILS

ROUNDED CHASSIS CORNERS

INSTRUMENT GAUGES

FUEL LEVEL GAUGE IN CAB

ELECTRICAL SYSTEM - COMPONENTS IN ONE  
LOCATION

ROTO CAST SEAT - ADJUSTABLE WITH BACK SUPPORT

REPLACEABLE CHASSIS SIDE PANELS

TURN SIGNALS

### PERFORMANCE:

STAIR TREAD WIDTH 48"

PLATFORM WIDTH 48" X 60" DEEP

STAIR HEIGHT 96" TO 150"

MAX SPEED 20 MPH

### SHIPPING DIMENSIONS:

LENGTH 270.00"

WIDTH 83.00"

HEIGHT 132.00"

WEIGHT 6700 LBS